

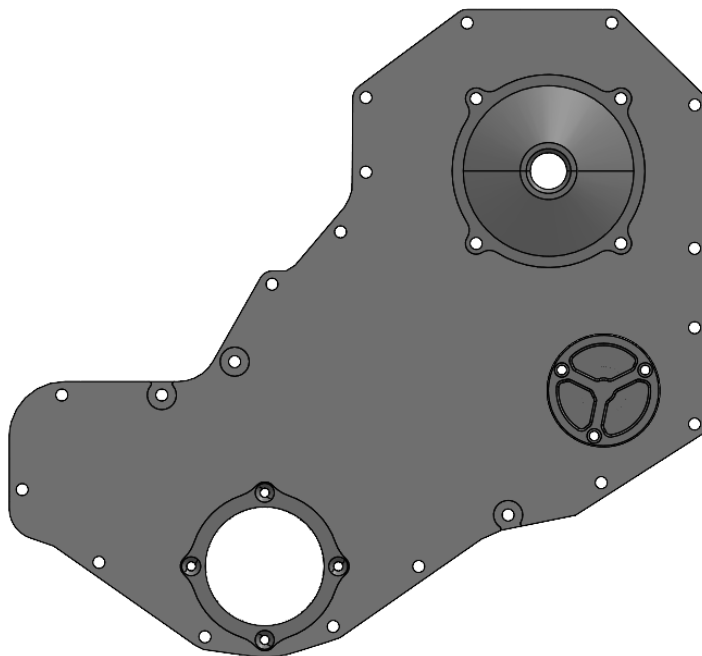

# 12V 2<sup>ND</sup> GEN FRONT TIMING COVER

P/N 012510-3V2



**Fits:**

- 1994 to 1998 12-Valve 5.9L Cummins engines with a P-Pump

**Does Not Fit:**

- 1993 and earlier engines with a VE Pump
- 1998.5 to 2002 24-Valve engines with a VP44 Pump
- Common rail engines

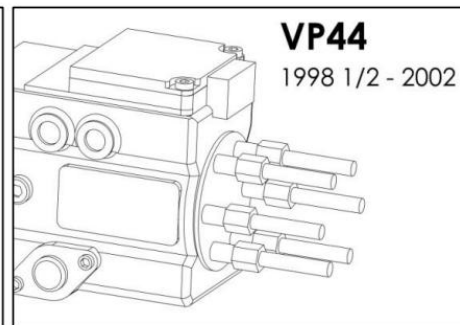
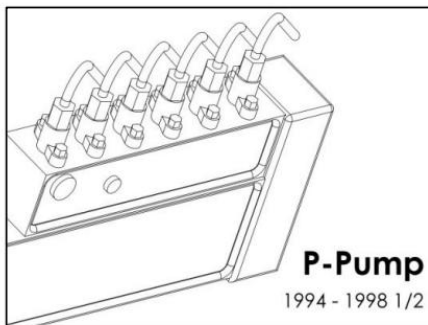
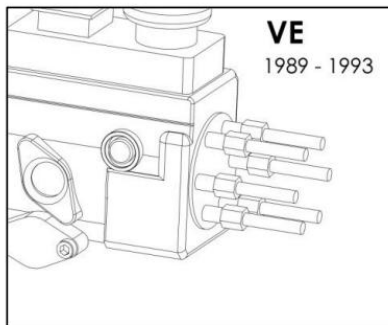

**Features:**

- Billet machined construction.
- Removable crank seal retainer.

## **Installation Instructions**

1. Clean area around original cover to prevent contaminants from entering the engine.
2. Remove any components required to access the timing cover (see engine service manual for details on disassembly and reassembly).
3. Remove original timing cover.
4. Inspect gear housing and remove any contaminants.
5. Clean and inspect gear housing sealing face to confirm none of the original gasket or other debris is present.
6. Confirm the O-ring is installed in the P-pump cover, Waterman pump block off, and Crank seal retainer

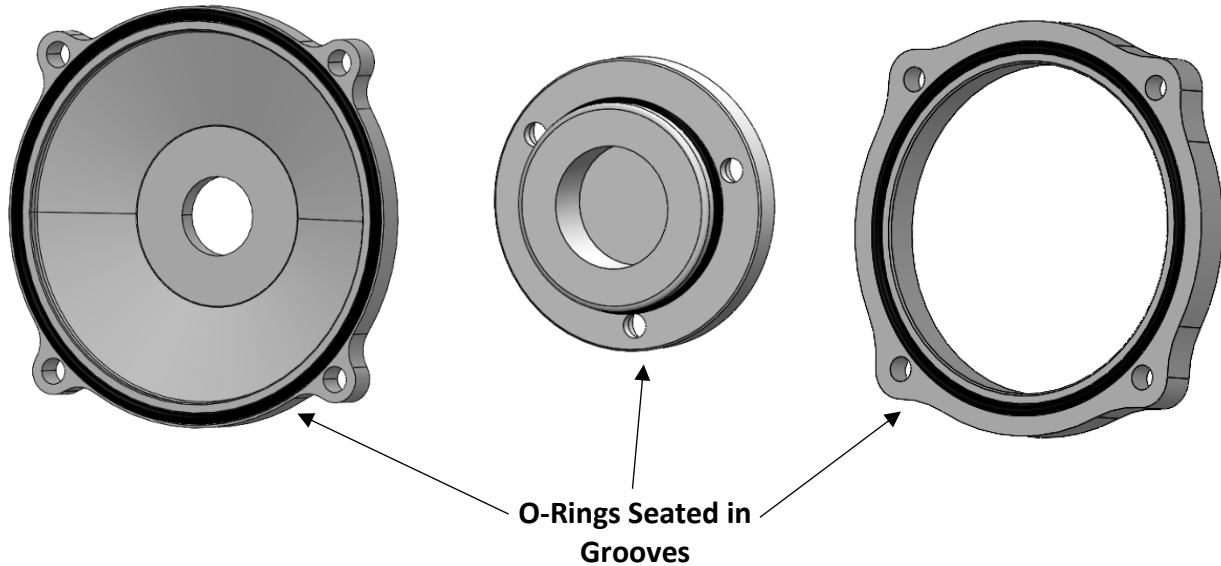

7. Install the waterman pump block off to the timing cover using socket head bolts.

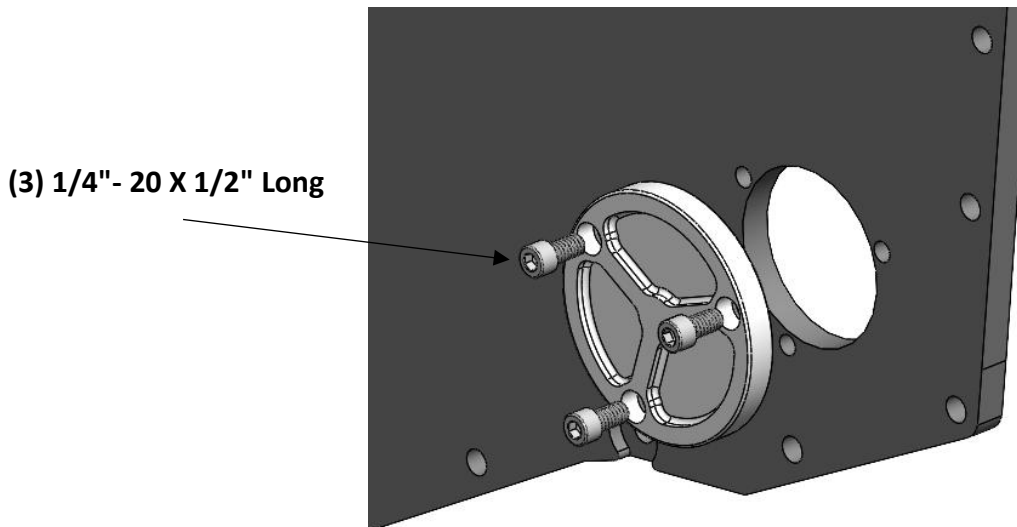

**Use Loctite® 242 or 243, then torque to 7 Ft-Lbs or 84 In-Lbs**

8. Install the P-Pump cover to the timing cover using socket head bolts.

(4) M8 X 1.25 X 20MM  
LONG

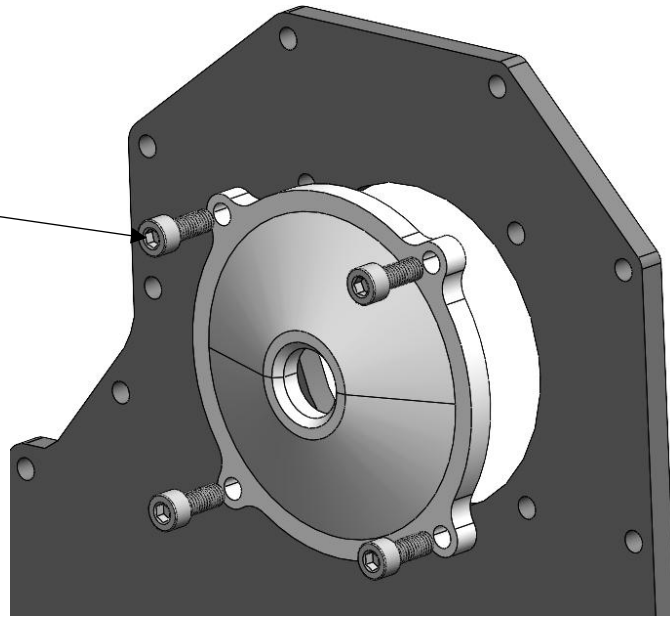

Use Loctite® 242 or 243, then torque to 18 Ft-Lbs or 216 In-Lbs

9. Install the timing cover onto the gear housing with a factory gasket. Bolt locations are as shown.

- a. M8x25 Flat Head: 1-7, 10, 11, 17
- b. M8x55 Socket Head: 8, 15
- c. M8X60 Flat Head: 9, 12-14, 18-20
- d. M8X20 Socket Head: 16

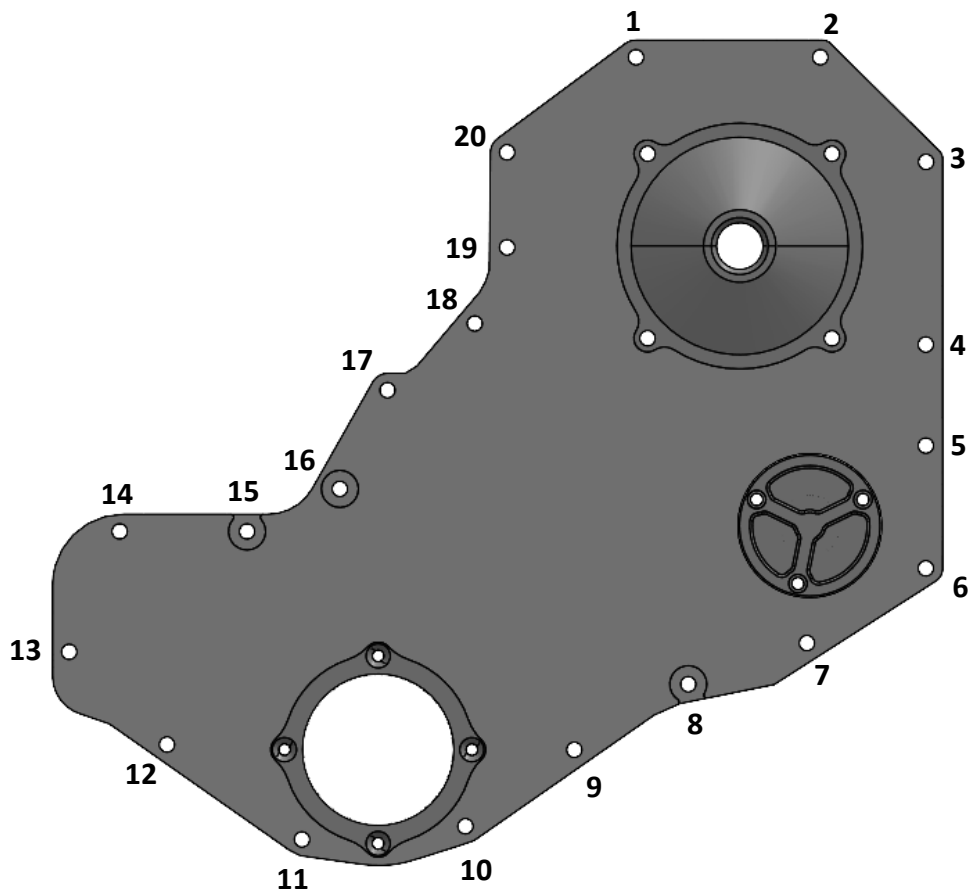

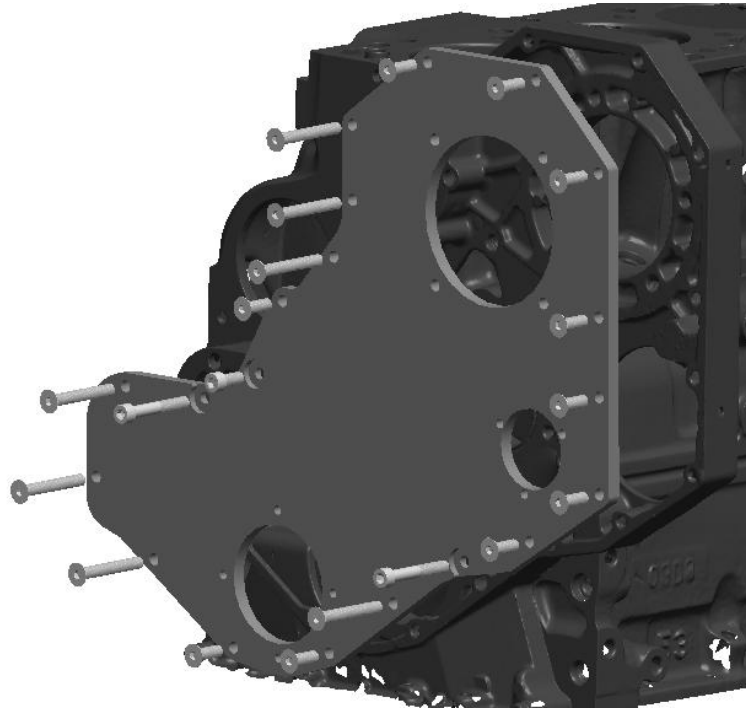

Use Loctite® 242 or 243, then torque to 18 Ft-Lbs or 216 In-Lbs

10. Install the crank seal into the crank seal retainer.
  - a. Remove the installation sleeve from the seal.
  - b. Align the crank seal with the front of retainer as shown.
  - c. Use the steel installation tool to press the crank seal into the retainer.
  - d. Make sure the seal is installed flush with the front face of the retainer.
  - e. Re-insert the installation sleeve into the seal.

**Correct seal orientation**

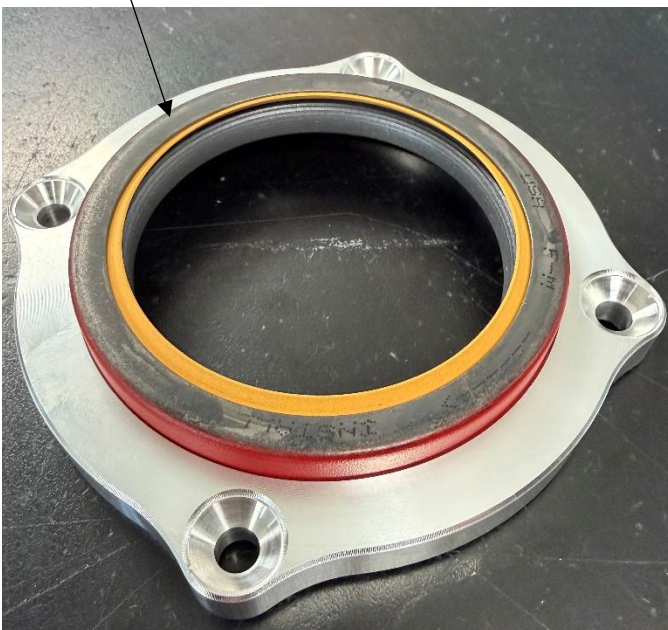

**Installation Tool**



11. Install the crank seal and crank seal retainer.

- a. Slide the seal onto the crankshaft using the installation sleeve to spread the seal.
- b. Bolt the crank seal retainer onto the timing cover.
- c. Pull the plastic installation sleeve out of the crank seal.

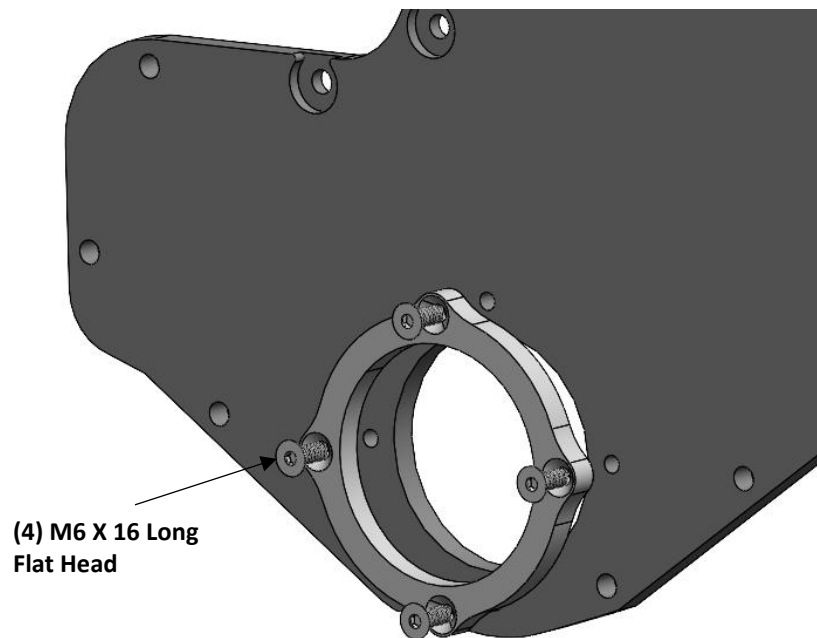

**Use Loctite® 242 or 243, then torque to 7 Ft-Lbs or 84 In-Lbs**

12. Reinstall any components that were removed before installing the timing cover (see engine service manual for details on disassembly and reassembly).

13. Check for leaks before and again after driving the vehicle.

Keating Machine, Inc.  
279 JD Yarnell Industrial Pkwy  
Clinton, TN 37716  
**(865) 599-6499**  
[sales@keatingmachine.com](mailto:sales@keatingmachine.com)