

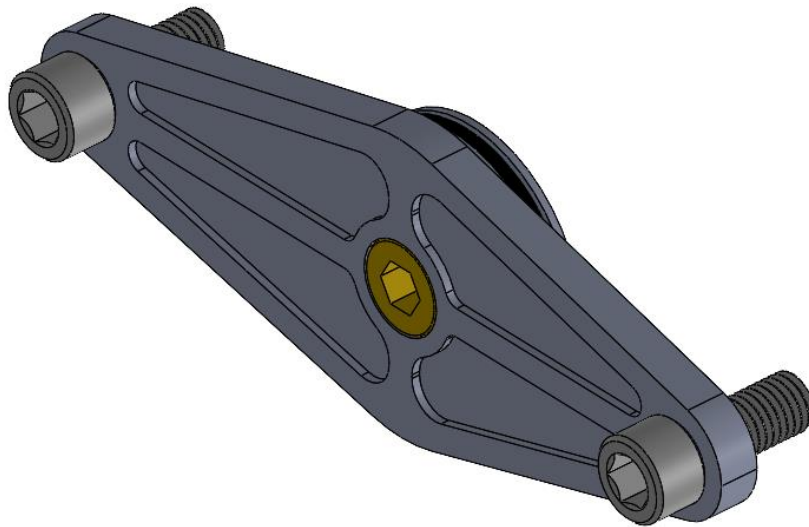

12V Cummins Rear Freeze Plug

P/N 122910-1P



Features:

- Billet machined construction with decorative pocketing
- Bolt-in mounting
- ½" NPT port for option to run coolant bypass
- Replaceable O-ring seal

Installation Instructions

1. Remove the factory press-in freeze plug
2. Clean the freeze plug bore for a smooth sealing surface
 - a. Make sure there is no pitting on the bore
3. If you are not running a coolant bypass, put pipe sealant on the brass plug and tighten into the freeze plug
4. Put a light coat of grease on the freeze plug O-ring
5. Press the freeze plug into the bore and align the bolt holes with the threaded holes in the block
 - a. Make sure the O-ring stays seated in the groove

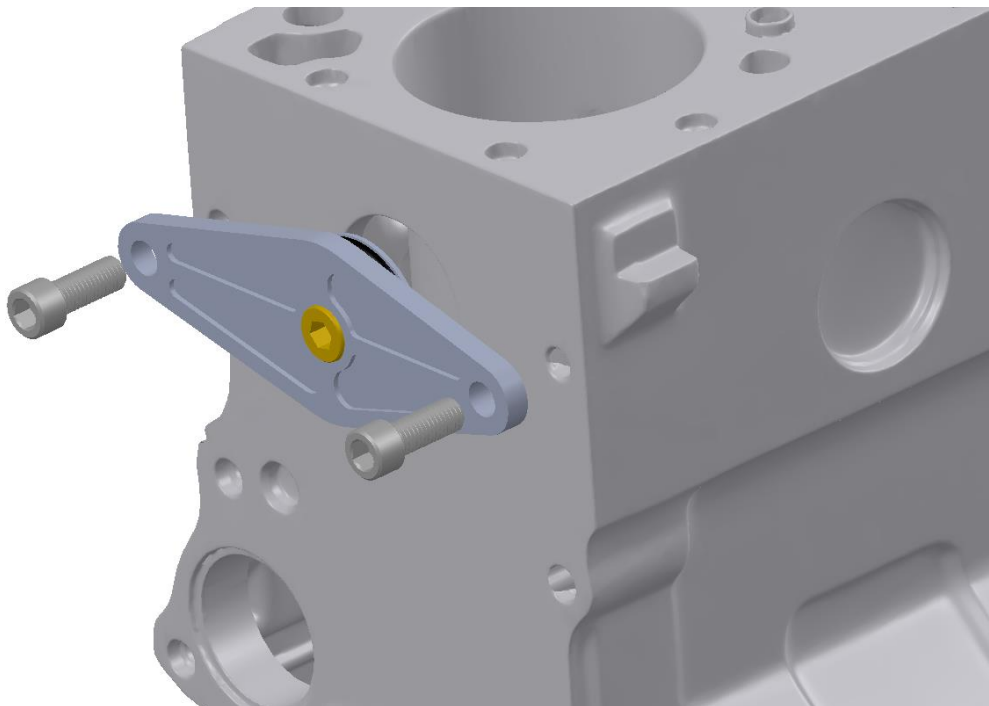

6. Put Loctite 242 or 243 on the bolts

7. Install the bolts and torque to a maximum of 45 ft-lbs

